

## COMPUTER AIDED DESIGN OF OVERHEAD CRANE IN HEAVY MECHANICAL COMPLEX

M Shahid Khalil<sup>ab</sup>

<sup>a</sup>Heavy Mechanical Complex Ltd, Ministry of Industries & Production, Government of Pakistan, Taxila, Pakistan

<sup>b</sup>H#2, Street # 15, F-6/3, Islamabad, Pakistan

(Received 26 October 1995; accepted 26 May 1999)

HMC is playing vital role in country-wide proliferation of the technology. It is involved in designing and manufacturing of various plants and heavy machinery. Cranes are also included in the HMC manifold. This paper explains the methodology of converting the conventional design process of overhead cranes to Computer Aided Design (CAD), software engineering approach and the usage of different tools in order to get a computer based solution for the design of overhead cranes. Applications of parametric design and design for manufacturing concepts may also be seen. The main idea is to automate the drafting process by linking it to design and analysis phase.

**Key words:** CAD, Overhead crane, Customization.

### Introduction

Crane is a cyclic action machine intended for hoisting or lifting and moving in space of load suspended by means of a hook or other load handling device (Annon 1970).

**Main parts of crane.** Parts of a crane (Annon 1970) which are manufactured by HMC given as below:-

Main Girder, Trolley (Double Girder), End Carriage, Foot Walk, Cabin, Driving/Driven Wheels, Main Power Supply (Open Bare Conductor), Electric Control Panels.

**Conventional methods.** HMC is an engineering company which designs and manufactures crane of various capacities. It is manufacturing Heavy and Light Duty Cranes with single and double girders. It is a main supplier of cranes in Pakistan to its customers. Customers have their own design specific requirements. Main specifications of a crane are its capacity, lifting height and span length.

If capacity or span length of a crane changes, the design will also be changed (Joseph Edward Shighley 1986). It means the hectic work of design calculations will follow again to meet the specific requirement of a customer. Such type of laborious work involves number of people to do hand calculations, drafting of drawing of different parts and its assemblies. It is time consuming and requires lot of motivation to pursue people to do their jobs. Therefore the date committed by the marketing

personnels to supply products for the customer need is not at all easy to meet. Hence disadvantages of a conventional design method could be given briefly as follows.

Time consuming, targets may not be met, errors possibility, inaccuracy, low efficiency, low output, hectic labor, drafting of drawings and hand written notes not consistent, repetitive task required for the same efforts

**Main strategy.** The theme of this work was a novel technique. It was involved the calculation of each component of a crane. The group of some parts are sub-assembly and sub-assemblies of the require capacity of crane (Annon 1970). The computer interact program which worked in the Auto CAD environment (Annon 1992) made a powerful CAD package. It could be used for analysis, drafting, costing and the generation of Bill of Quantity (BOQ). The schematic diagram is shown in Fig 1.

**Group task.** The development of Computer Aided Design work was a team work. Number of people were involved for the design of a crane. This team was comprised of engineers, supervisors and draftsmen. People were working on the

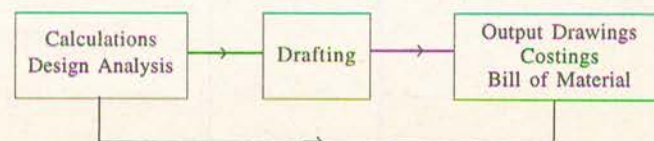

Fig 1. The schematic design of the basic theme and strategy.

<sup>b</sup>Present address.



design of crane for a long time. Thus to extract informations from them for the development of CAD package were more difficult than to work on the conventional procedure. To develop the software for the design of Main Girder, End Carriage etc. one has to have a clear picture of all the design calculations and dimensions of all crane parts. For the CAD work of crane the database of all type of equipments, plates, rolled sections, fasteners, motors hoists, etc were also required.

The development of software work could only be possible after intensive discussions with designers and draftsmen. When all the detail of objects were obtained, the programming in Autolisp language (George Omura 1990) was carried out. The number of lisp functions were developed and loaded in the environment of AutoCAD version 12. On execution of computer programs, design and drafted results were stored in the computer hard disk and results ready to available for printing and plotting.

### Materials and Methods

*Rules and standards.* There were so many design points and other remedies that were understood during this customization procedure. At many stages, needful information was missing therefore number of rules were developed. Conventional design procedure work was important at the start of programming. Two to three different design (Salisbury 1950) cases were studied to make the general program. Metric units were used for the development of this software. The program asked number of inputs to show its compatibility as a general design program for different users.

The tiresome calculations work were embedded in the form of Autolisp programming (George Omura 1990) which is now a great asset for the organization. The botheration of hand calculations and to find values from thick and heavy references manual, were no more required. Thus this CAD program could be used as a standard tool for the design purposes of Single and Double Girder crane which would be beneficial and worthy for the HMC. This program may also be important for other manufacturing and production organizations.

*Schematic design of crane.* The part list of a crane was already given above. The design procedure for each object using CAD technique is discussed as follows:-

*Main girder.* It was a main part which was designed with I-section beam for single crane and box section (using plates) for Double Girder crane (Annon 1970). For the design of Main Girder (for example), the program asks from the user.

- Please enter the span of crane
- Please enter the capacity of crane

After taking the above respective values, the maximum (max) load was calculated on the section of Main Girder. In return the max shear, max bending moment and the section modulus were calculated (Mohan Devan 1989). With the section modulus of a required I-section beam, the safe deflection of the girder was found out for the required capacity of a crane. The iteration method (George Omura 1990) was also followed for the selection of a cross section for Single and Double Girder Cranes. When the required I-section (e.g. IPE, HEA, HEB) was selected, the drawing of the Main Girder was appeared on the computer screen.

Standards were also followed for the drafting of drawings of the Main Girder and its assembly. Line types like continuous, dash, central etc with different colors were used for the drafting of elevation and plan views. Dimensioning was also done in the dimension layer. All AutoCAD commands (Annon 1992) were included in the programming to draw the main girder. The Stahl standard has limitations to design Single Girder Crane which should not be exceeded 17 meters span length and 10 tons capacity. If the specification changes to greater values, the Double Girder Crane (Annon 1970) could be used. In a similar fashion, the Double Girder Crane of any capacity and span length could be designed.

*End carriage.* The procedure to design and carriage was also similar to the above design procedures. The wheel base of end carriage depends on the span length of main girder. Box section was used for the construction of End Carriage made of C-section channels. Same layers with standard colors were also used as above for the drafting of the end carriage and its assembly.

In the design of end carriage, the iteration method was also used to select a cross section of the required channel. This procedure (Annon 1996) was important for the selection of box section and wheel assembly. The purpose was that the load bearing by the end carriage on the driving and driven wheel were clear enough to travel smoothly, with the lifting load on the Main Girder.

*Driving/driven wheel.* The crane wheel was designed to consider total weight of the main girder, capacity of crane, trolley weights etc to calculate load per wheel for the safe design (Mohan Devan 1989). The calculated load on each wheel would be changed if above parameters were also changed. When the max load on each wheel was calculated, design calculations and all AutoCAD's command to draft the wheel and its assemblies were programmed for the executions.

*Bridge assembly.* Bridge assembly was consist of Main Girder and End Carriage assemblies. Lisp functions were



already written above for the design and drafting of these items. Therefore, these functions were called for the design and drafting of bridge assembly. Layer standards (Annon 1992) and units were also followed for the bridge assembly.

*Main assembly of crane.* Steps to follow the schematic design of crane for Single Girder is shown in Fig 2. Each step in the block diagram represents different objects to design for the sub-assembly e.g. the end carriage assembly was consist of Wheels and End Carriage frame etc (Annon 1970).

If all sub-assemblies would be assembled it will make a Single Girder Crane. Therefore, a final lisp routine was written to call above functions to draft the main assembly of a crane. Bus bar arrangements and electrification for the traveling of trolley with a lifting load were also encountered in the assembly.

*Double girder crane.* In view of the above design procedures, the Double Girder Crane was also designed which was known as Heavy Duty Crane. The schematic design of this crane is shown in Fig 3. Step by step procedure for the design of Double Girder Crane was also similar to the design of Single Girder Crane (Fig.2). Moment of Inertia was cal-

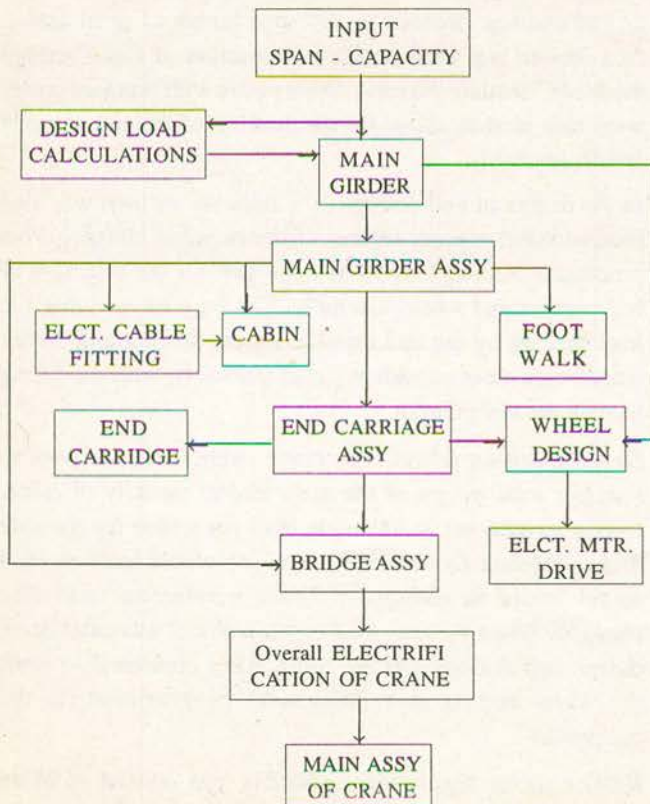

Fig 2. Schematic design of Single Girder Crane.

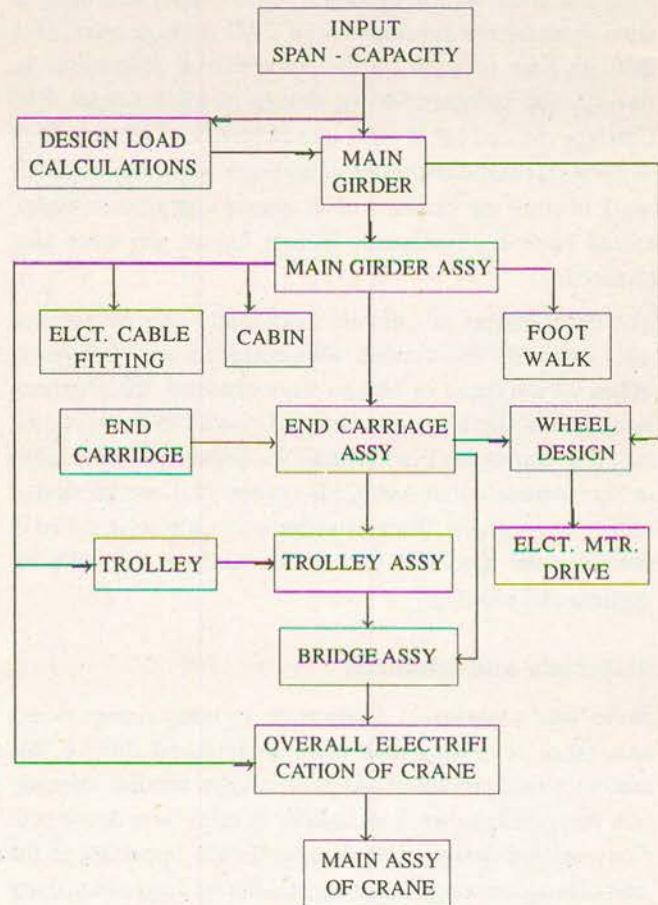

Fig 3 Schematic design of Double Girder Crane.

culated (Mohan Devan 1989) for the Box Section of main girder, where as standard values of moment of inertia were used for rolled sections. Design calculations for the box section of Main Girder, End Carriage, Trolley, Foot Walk etc were quite time consuming. When all the paper work for design of Double Girder was completed, the lisp routines (Georhe Omura 1990) were written to design and draft the above crane.

**Results and Discussion**

*Modular approach.* The strategy discussed above was done in modular fashion. Different modules have been programmed for example "Single" module for the design of Single Girder Crane and the "Double" module for the design of Double Girder Crane. Whereas other modules were also developed for the generation of "Bill of Quantities" (BOQ) and "Costing" etc.

BOQ module was designed to calculate total tonnage capacity of the material which was used in the fabrication of Main Girder, End Carriage, Wheel Assembly etc. This function also calculate unit and total weight of each plate, rolled



section, nut, bolt etc. to construct "Bill of Quantity" for each designed drawing. This sort of work was used to take long hours and involve number of people to calculate the above items. There were chances of error which have been minimized and solved efficiently using the CAD technique. In the same way "Costing" work was also done and calculated the total cost for the manufacturing of Single and Double Girder Cranes.

The "modules oriented work" for the manufacturing of cranes were advantage on the part of CAD users. CAD works very fast which executed drafting of drawing, BOQ, and costing in short interval of time but on the other hand the same work used to take a number of months. The hand calculation and hand drafting work could have the possibilities of error. Hand written notes might, be not legible and usually create problems on the shop floor or on costing side etc. Whereas the output generated by the CAD work using plotter were standardized and legible.

The main advantage of modular programming was to improve the quality of work, debugging for errors and program upgrading. The "Novel" technique of such development work has opened efficient and accurate methods for drafting and manufacturing. The data obtained for the machining items like driving and driven wheels (Salisbury 1950) etc. could be readable by the CNC machines proposed to use in future. The above task was not easy, but thanks to CAD technology, that efficient way of designing is not beyond the human reach.

*Present resources.* The resources required for the CAD of Crane were not expensive and available without much efforts:-

- AutoCAD Ver 12.0 for the project
- Autolisp language for programming
- For-Pro for database storage of crane
- Recommended 386/486 computer machine
- Recommended laser/dotmatrix printer for quick hard copy of drawings/sting
- Plotter for final drawings

The AutoCAD package was chosen because it was simple and easy for the customization and software development. AutoLisp i.e. its programming language was simple to learn. This program could be loaded on 80386 or 80486 processor machines and easily run by engineers, scientists etc. to use it for their requirements.

*Implementations of CAD work.* The implementation of

above work as easy. All the program files were saved and properly backed up which could be used in case of files became corrupt. There were three 486 computers installed in the crane section. AutoCAD version 12 and the CAD software were also loaded on these machines.

The design work of crane using CAD software was already been started in the design department and found very efficient and productive. On the execution of program, the design and drafting of all drawings of any capacity of crane were generated. Drawing files were loaded on Auto CAD program and plotted using HP Designjet 600 plotter. All the drawing were standardized and legible. These drawings were used to send Production Planning Deptment (PPC) and to the Works Department (i.e. on shop floor etc.). The procedure of designing of crane through this technique was efficient, reliable and error proof.

It is very important to mention that it is a development work which saves not only the time and money but as a whole to keep the design standrds up in HMC. The crane software applications will also help to boost the design and manufacturing activities of crane and ready to have a better competition in the market.

### Conclusion

The above discussion of conventional design which leads to the CAD of crane has developed a very useful design software. Using this package the repetition work was avoided. The design work was efficient, accurate and error free. The advantage of the software was that any capacity or any span length would be designed without much efforts. Second main advantage was that all drawings of the required specification will be available in a short interval of time and ready to plot as a hard copy. Hence the above discussions could be tabulated briefly as under:-

Time saving, Precision, Ease of designing, Easy to use, Error proof, Greater efficiency, Automatic generation of Bill of Quantities, Quick output of drafted drawings, Standardized drawings, Accurate costing of the design products.

### References

- Annon 1970 *Section I Heavy lifting equipment.* Federation Europeane de la Manutention. Rules for the Hoisting Appliances 2nd Ed Paris France.
- Joseph Edward Shigley 1986 *Mechanical engineering design*, McGraw Hill, New York USA pp 94-124.
- Annon 1992 *Autocad reference manual version 12.0.* Autodesk Inc. USA pp 30-50.
- George Omura 1990 *The ABC's of autolisp*, Tech Pub,



Singapore pp-40-70.  
Salisbury 1950 *Kent's mechanical engineering*. John Willey  
& Sons USA pp 25-54.  
Mohan Devan 1989 *Design data*. Publishers New Dheli India  
pp 212-230.

Annon 1996 *Design procedure manual*. Procedure No.  
DD01016 HMC Taxila pp 10-90.  
Annon 1992 *Microsoft foxpro manual*. Microsoft Corpora-  
tion Redmond USA pp 10-84.